



HYPER 31 DTH HAMMER

Technical Brochure



Certificate Number 2446/00
ISO9001

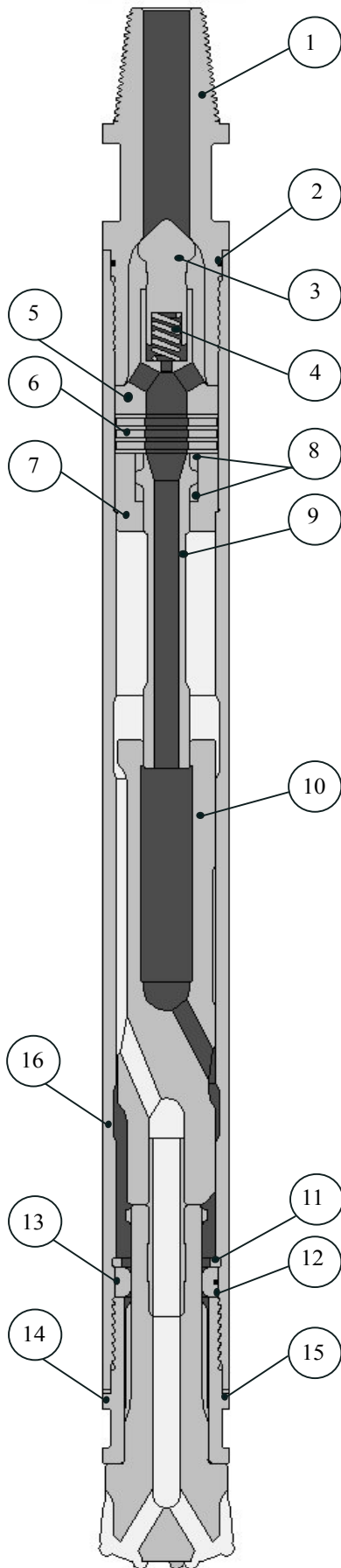

Hyper 31 Valveless Hammer

90mm (3 1/2") - 100mm (4") diameter holes

The Hyper is a valveless D.T.H Hammer designed for drilling 90mm-100mm (3 1/2" - 4") diameter holes over a wide range of operating air pressures. The Hyper 31 is supplied with a 2 3/8" API reg. pin backhead as standard but other connections are available on request. A positive fitting water check valve guards against ingress of ground water when the air is shut off.

The Hyper 31 accepts as standard, the Mach 33 Button Bit, although bits with Mission A3015, and IR DHD 3.5 shanks can also be used by simply making a few minor component changes. Alternatively, the Hyper 31 can be supplied initially to suit any of these bits.

COMPONENT PARTS

Ref	Description	Part Number
1	Backhead	HSH31380M
2	Backhead 'O' Ring	IPBOR01
3	Check Valve	IPRCV01
4	Check Valve Spring	IPRCVS01
5	Diverter	HSH3120
6	Compression Buffer	HSH3128
7	Tube Holder	HSH3131
8	Tube Buffers x 2	HSH3129
9	Control Tube	HSH3130
10	Piston	HSH3103
11	Piston Retaining Ring	HSH3132
12	Bit Retainer Ring	HSH3137019
13	Bit Retainer 'O' Ring	IPBOR01
14	Chuck	HSH3135019
15	Chuck Release Washer	HSH3126
16	Wearsleeve	HSH3100
	Complete Hammer	BR31H03

HAMMER SPECIFICATION

	Imperial	Metric
Weight (less bit)	52.8 lbs	24 Kgs
Length (less bit)	34.56"	878 mm
Outside dia.	3.12"	79.2 mm
Piston weight	11.0 lbs	5 Kgs

AIR CONSUMPTION

PSI	BAR	C.F.M	Cu. Mtr / min
150	10.3	96	2.7
200	13.8	148	4.2
250	17.2	206	5.8
300	20.7	271	7.7



Bulroc (UK) Ltd.

Turnoaks Business Park, Burley Close, Chesterfield, Derbyshire, United Kingdom. S40 2UB

Tel : +44(0)1246 544700 Fax : +44(0)1246 544701

Email : info@bulroc.com Web: www.bulroc.com