



HYPER 51 DTH HAMMER

Technical Brochure



Certificate No. 2448/00

Hyper 51 Valveless Hammer

127mm (5") - 165mm (6½") dia. Holes

The Hyper 51 is a valveless DTH hammer designed for drilling 127mm-165mm (5" - 6½") dia. holes over a wide range of operating air pressures. The Hyper 51 is supplied with a 3½" API reg. pin backhead as standard but other connections are available on request. A positive fitting water check valve guards against ingress of ground water when the air is shut off.

The Hyper 51 hammer is designed to accept as standard button bits with a shank and footvalve identical to the Ingersoll Rand DHD 350R. However, the Hyper 51 can also be supplied to accept Mission SD5, Halco Mach 50, and QL50 types of button bits.

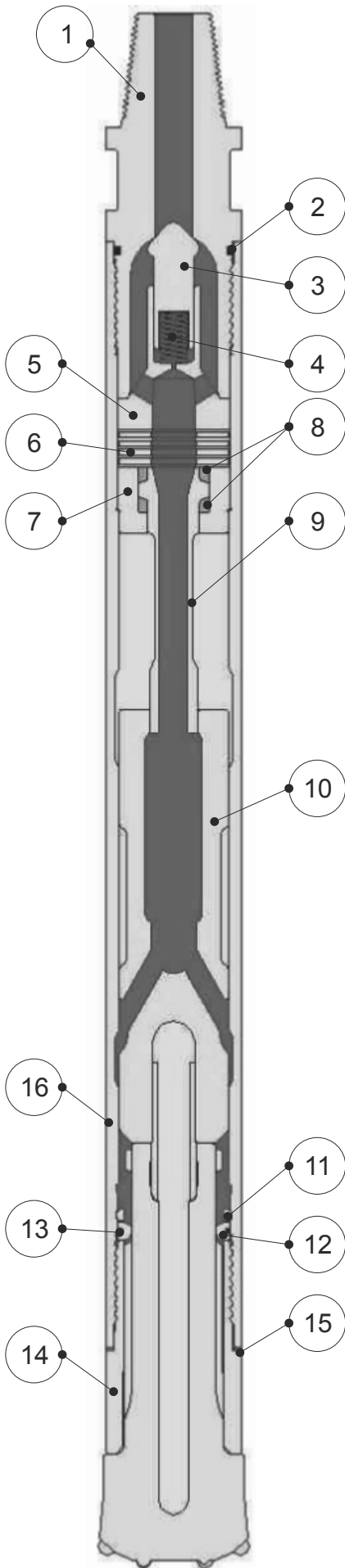

COMPONENT PARTS

Ref	Description	Part Number
1	Backhead	HSH513803M
2	Backhead 'O' Ring	HSH5114
3	Check Valve	IPRCV03
4	Check Valve Spring	IPRCVS02
5	Diverter	HSH5120
6	Compression Ring	HSH5128
7	Tube Holder	HSH5131
8	Tube Buffer (2)	HSH5129
9	Control Tube	HSH5130
10	Piston	HSH5103
11	Piston Retaining Ring	HSH5132
12	Bit Retainer Rings	HSH5137092
13	Bit Retainer 'O' Ring	HSH5137A092
14	Chuck	HSH5135092
15	Chuck Release Washers	HSH5126
16	Wearsleeve	HSH5100
Complete Hammer		BR51H01

HAMMER SPECIFICATIONS

	English	Metric
Weight(less bit)	133 lbs	60 kg
Length (less bit)	43.94"	1116 mm
Outside dia.	4.50"	114.3 mm
Piston weight	26.8 lbs	12.2 kg
Stroke	4.25"	108 mm

AIR CONSUMPTION

PSI	BAR	C.F.M.	Cu. Mtr / min
150	10.3	214	6.0
200	13.8	329	9.3
250	17.2	459	13.0
300	20.7	604	17.1